

EN C-04 LIFT LANDING DOOR RETIRING CAM MOUNTING-ADJUSTMENT-MAINTENANCE INSTRUCTIONS

MOUNTING-ADJUSTMENT

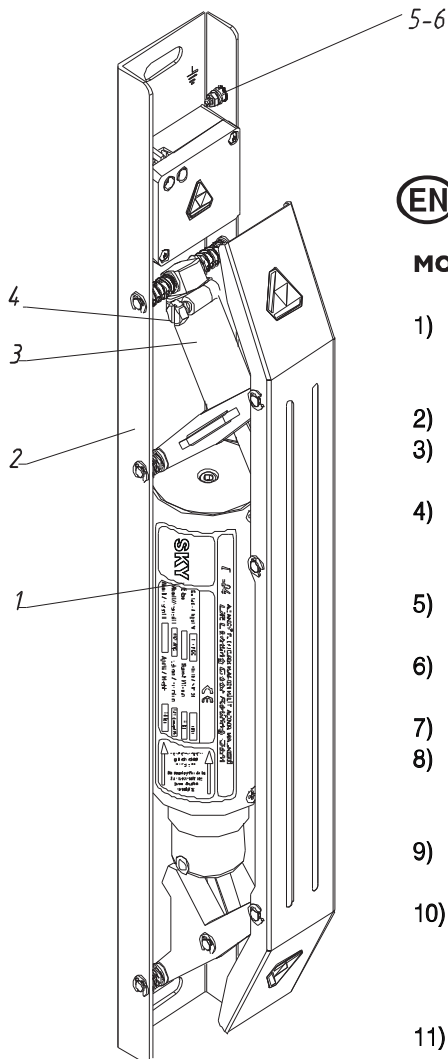

- 1) Take out the C-04 Lift Landing Door Retiring Cam, that you have bought, from its box and make the control of the feeding voltage and its kind on the label number 1. If you are sure, that it is one and the same with the feeding voltage and the kind of current of your installation (system), continue the mounting
- 2) During the mounting position, the arrows on the label number 1 must show upper direction, be careful.
- 3) Do the mounting of the magnet into its place in the lift cabin with the help of the slot holes, which are at the both ends of the below chassis number 2.
- 4) After completing the mounting, make the manual operation of the magnet, if there is any stitching or problem, contact to our company. If there isn't any problem during the manual operation, begin to do the electrical mounting.
- 5) Put the grounded cable where there is a grounding mark on below chassis number 2 by squeezing turnscrew number 6 on bolt number 5.
- 6) Put the ends of the other two cables (phase and neutral) in the free holes number 7 and by squeezing number 8 holes with a screwdriver, complete the electrical connection.
- 7) If it is possible, operate the magnet by application of voltage and control it.
- 8) For making the adjustment of the lock handle, there must be approximately free place of 3-5 mm between it and the lock handle when the C-04 Lift Landing Door Retiring Cam is closed. Make the control, if this free space is absent, make the readjustment of the lock handle.
- 9) The operation course of the C-04 Lift Landing Door Retiring Cam was adjusted as 33 mm. For its harmonious operation with the lock, make the lock handle adjustment carefully.
- 10) The operation speed of the C-04 Lift Landing Door Retiring Cam can be adjusted. If it makes any sound when the lock is opening with a speedy operation, you can slow down the operation speed a little bit by squeezing the speed adjustment screw number 4, that is situated on the speed adjustment cylinder number 3.
- 11) The minimum decrease of the speed by complete squeezing of the speed adjustment screw is not advised, because the magnet causes extreme heating by decreasing the pulling power of the bobbin.
- 12) The useful life of the product is 10 (ten) years, Two (2) years guarantee.

MAINTENANCE

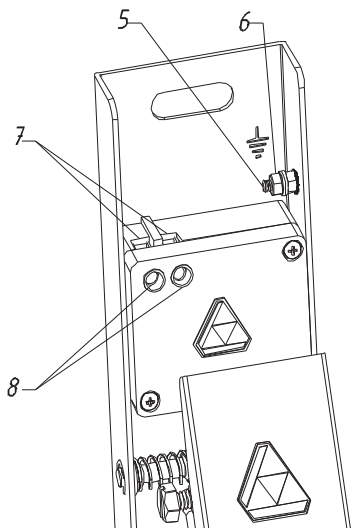

- 1) The dust, that was assembled in the operating parts, must be cleaned during the routine maintenance every month.
- 2) Because the oil on the operating shaft in the bobbin is heatproof oil, contact to our company, if it has to be oiled.
- 3) During the routine maintenance every month, make the control of the terms, described in the adjustment part. Redo the disassembled adjustment.
- 4) If any liquid comes to the operation environment due to cleaning or any other reason during the controls provide the doing away of this environment. The liquids, that can enter into the bobbins and the electrical connections, can cause short circuits.
- 5) If the cabin needs to be painted, dismount the C-04 Lift Landing Door Retiring Cam from its place. Remount it again after the painting procedure. Paints and solvents, that can enter in the operating parts, can damage the operation system.
- 6) Keep away from needless inventions, except cleaning, adjustment and the other ones, that were described in the above mentioned articles.
- 7) If necessary, contact with our company.